

SIRIO 5RZ48

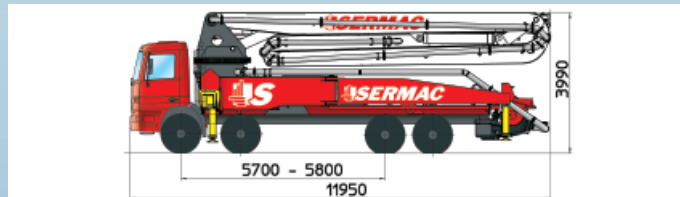
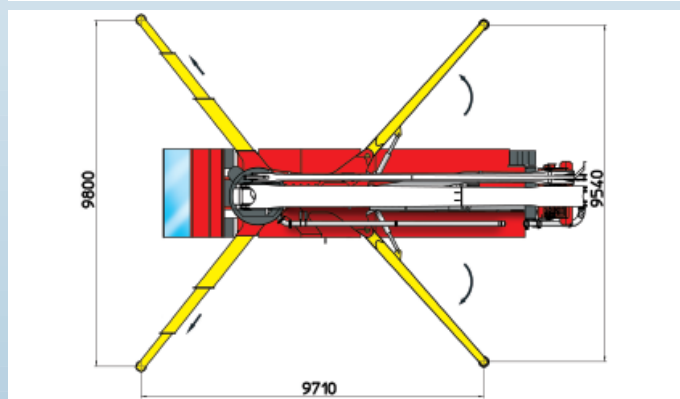
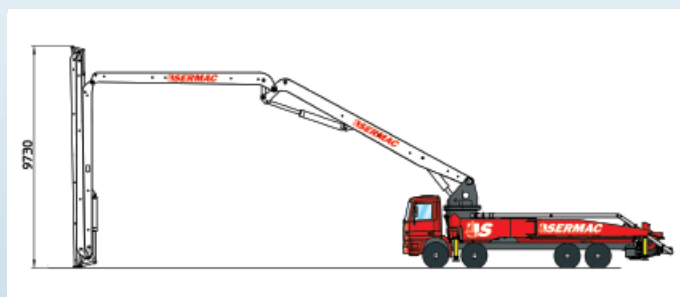
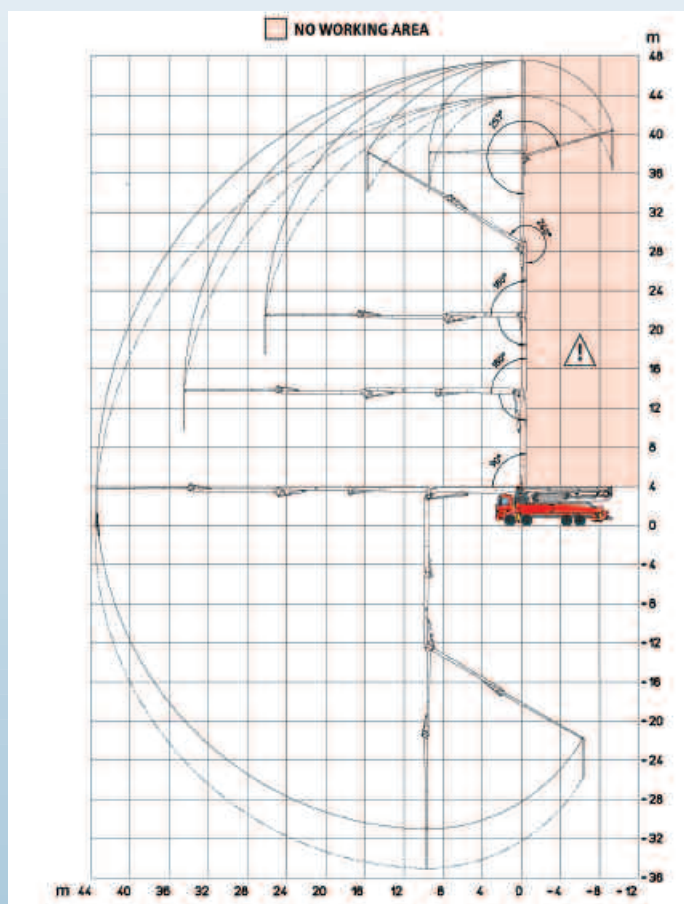

GRUPPO POMPANTE › dati tecnici PUMPING UNIT › SPECIFICATIONS

		SCL 130A	SCL 150AHP	SCL 185A
PORTATA MASSIMA TEORICA (MAX)* LATO STELO	TH. CONCRETE OUTPUT (MAX)* ROD SIDE	130 m ³ /h (170 cy/h)	149 m ³ /h (195 cy/h)	184 m ³ /h (241 cy/h)
PRESSIONE SUL CALCESTRUZZO (MAX)* LATO STELO	CONCRETE PRESSURE (MAX)* ROD SIDE	61 bar 884 p.s.i.	76 bar 1102 p.s.i.	61 bar 884 p.s.i.
CORSE AL MINUTO (MAX)* LATO STELO	NO. OF STROKES (MAX)* ROD SIDE	27 min	30 min	37 min
DIAMETRO PISTONI	PISTON DIAMETER	230 mm	230 mm	230 mm
CORSA PISTONI	STROKE LENGTH	2000 mm	2000 mm	2000 mm
POTENZA TRAMITE	POWERED BY	PTO	PTO	PTO
CAPACITÀ TRAMOGGIA	CONCRETE HOPPER	600 l	600 l	600 l

BRACCIO › dati tecnici BOOM › specifications

		5RZ48
N. SEZIONI	NO. SECTIONS	5
TIPO APERTURA	FOLDING TYPE	RZ
MAX ALTEZZA VERTICALE	MAX VERTICAL REACH	47,5 m
MAX ESTENSIONE ORIZZ.	MAX HORIZONTAL REACH	43,2 m
MAX PROFONDITÀ DI LAVORO	MAX DOWNWARD REACH	-35 m
MIN. SPAZIO DI APERTURA	UNFOLDING HEIGHT	9750 mm
ROTAZIONE	ROTATION	370°
ANGOLI DI APERTURA	SECTION ARTICULATION	90° - 180° - 180° 240° - 253°
TUBAZIONE CLS	CONCRETE PIPELINE	Ø 125 mm

*Non possono essere ottenuti simultaneamente
*Cannot be reach simultaneously

› Disponibili anche versioni differenti: per eventuali informazioni contattare i nostri uffici.
› Also available different models: please, don't exitate to contact our offices.