

# nifty

## **SD120T** **SELF DRIVE** **ACCESS PLATFORM**



**12.20m (40ft)**  
Working height

**6.10m (20ft)**  
Working outreach

**Weight Saving Design**  
Easily transported & manoeuvred on site

**Telescopic Upper Boom**  
Greater accuracy when positioning the platform

**Bi-Energy Available**  
Optimises utilisation

**Fully Proportional Hydraulic Controls**  
Quick & easy to service

**Hydraulic Outriggers**  
Quick & easy to set up



**niftylift.com**



# nifty SD120T

The **SD120T** delivers an impressive working envelope and with the advantage of a telescopic upper boom, supreme accuracy when positioning the platform. Hydraulic outriggers and 45% gradeability allow it to be driven and levelled on uneven surfaces making it ideal for environments with rough or softer ground and its low overall weight means better fuel efficiency and lower transportation costs.

## SAFETY FEATURES

- Pressure sensitive outriggers with
- Audible & visual alarms
- Dual controls (platform & base)
- Manual descent with hand-pump
- Lock valves on all hydraulic cylinders
- CE Mark

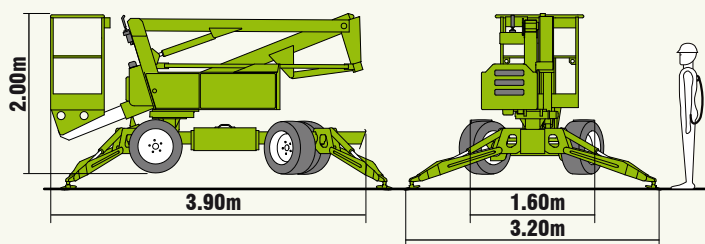
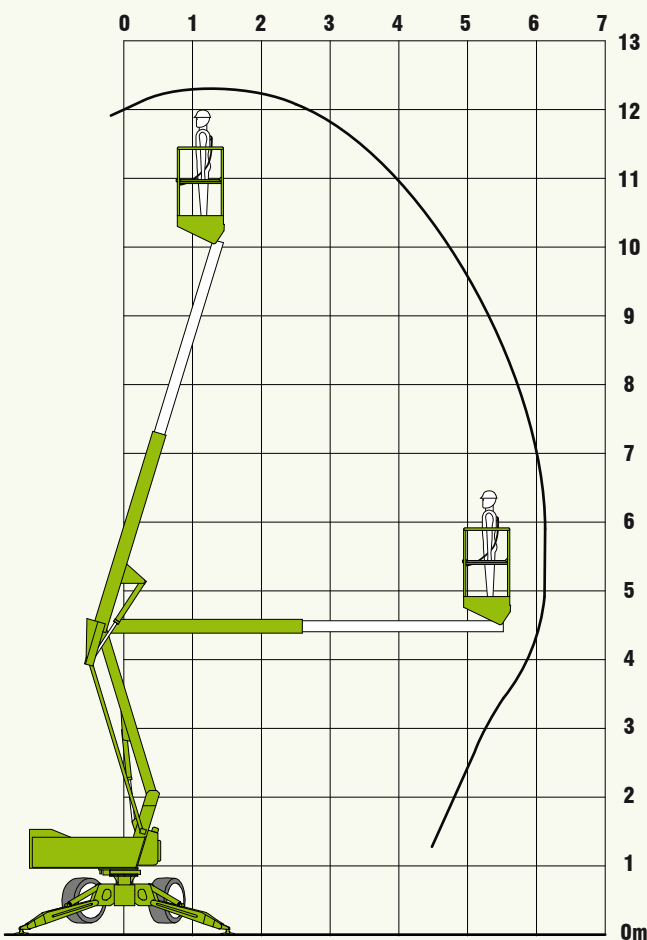
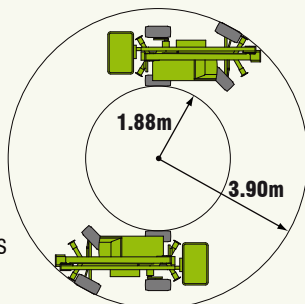

Niftylift's highly effective **Bi-Energy** system increases flexibility and maximises utilisation allowing the **SD120T** to operate for longer and in a wider range of environments.



## SPECIFICATIONS

<b>Working Height</b>	12.20m	40ft
<b>Platform Height</b>	10.20m	33ft 6in
<b>Working Outreach</b>	6.10m	20ft
<b>Slew</b>	406°	
<b>Width - Travelling</b>	1.60m	5ft 3in
<b>- Working</b>	3.20m	10ft 6in
<b>Height</b>	2.00m	6ft 7in
<b>Length</b>	3.90m	12ft 10in
<b>Minimum Weight</b>	1850kg*	4080lbs*
<b>Turning Radius - Inside</b>	1.88m	6ft 2in
<b>- Outside</b>	3.90m	12ft 10in
<b>Platform Capacity</b>	200kg	440lbs
<b>Platform Size</b>	1.10m x 0.65m	3ft 7in x 2ft 2in
<b>Drive Speed</b>	4.0kph	2.5mph
<b>Gradeability</b>	45%	
<b>Control System</b>	Fully Proportional Hydraulic	
<b>Power Options</b>	Battery Only Petrol or Diesel Only Bi-Energy (Engine and Battery)	

\* Weights may vary according to specification / power options, please confirm before ordering.

Due to a policy of continuing development and improvement, Niftylift reserves the right to change any specification without notice. Please confirm exact specification before ordering.

Supplied by:

IS-01

**Manufacturers of trailer mounted,  
self propelled and vehicle mounted platforms.**

**NIFTYLIFT LTD**  
Fingle Drive  
Stonebridge  
Milton Keynes  
MK13 0ER  
England

www.niftylift.com  
e-mail: info@niftylift.com  
Tel.: +44 (0)1908 223456  
Fax: +44 (0)1908 312733

