

LT 35H UNIMOG

...NON ESISTONO BARRIERE
...NO MORE BARRIERS



LT 35H UNIMOG è un'autobetoniera "FUORISTRADA" da 3 m³, compatta, di potenza elevatissima in grado di trasportare calcestruzzo pronto all'uso nei cantieri più estremi.

È ideale: - in condizioni di lavoro **estremamente difficili**
- quando il **cantiere è irraggiungibile con i normali mezzi d'opera**
- quando si richiede **calcestruzzo di altissima qualità** in cantieri dove normalmente si opera solo manualmente

The **LT 35H UNIMOG** is a "OFF-ROAD" compact truck mixer with 3 m³ payload, mounted on a very powerful vehicle that can transport ready-mixed concrete in the most extreme building site.

It is ideal: - in **extremely difficult** working environments
- whenever the building site **cannot be reached with normal trucks**
- whenever you require **high quality concrete** in buildings sites where you normally operate manually



Serbatoio acqua pressurizzato con marcatura CE (optional)

Pressurized water tank with CE certification (option)



Il riduttore è epicicloidale a 2 stadi. La trasmissione è idrostatica a circuito chiuso composta da una pompa a pistoni assiali, da un motore a pistoni assiali con trasduttore di velocità integrato e sistema elettronico CSD (**Constant Speed Drive**)

2 stage epicyclic gear-box. Hydrostatic transmission with closed circuit consisting of a pump with axial pistons, a motor with axial pistons and integrated speed transducer, CSD electronic system (**Constant Speed Drive**)

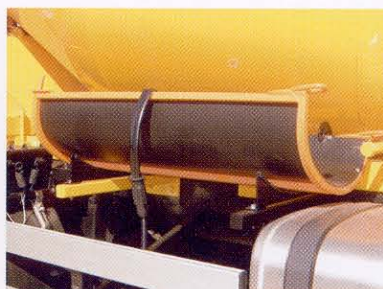

Prolunga superleggera in polystone e barriere paraciclista
Superlight polystone extension chute and cyclist side-protection



Pulsantiera ergonomica **JOY** user-friendly
Ergonomic and user-friendly **JOY Pushbutton controls**

caratteristiche distintive outstanding characteristics



Scambiatore di calore con filtro e serbatoio olio incorporato
Heat exchanger with built-in filter and oil tank



Blocco meccanico antirotazione per rendere sicuri gli interventi di manutenzione del tamburo
Mechanical lock against rotation to allow maintenance of the drum in full safety



Distributore idraulico per comandi
Hydraulic controls with distributor



Scala ergonomica
Ergonomic ladder

IL TAMBURO DI MESCOLAZIONE DELLE AUTOBETONIERE L&T È REALIZZATO IN ACCIAIO ANTIUSURA 30MnB5: L'ACCIAIO CHE DURA REALMENTE DI PIÙ

L'acciaio 30MnB5 ha caratteristiche chimiche e meccaniche assolutamente superiori rispetto agli acciai comunemente utilizzati. L'alto contenuto di Cromo e Boro è la garanzia di una vera resistenza all'usura, sia meccanica che chimica, causata dal calcestruzzo.

Tipologie acciai

30MnB5: acciaio antiusura utilizzato per la realizzazione dei tamburi delle nostre autobetoniere
27MnB5 (TBL2A): acciaio antiusura per macchine agricole, erpici, aratri
Fe510: acciaio comunemente utilizzato per costruzioni meccaniche

THE MIXING DRUM OF THE L&T TRUCK MIXERS IS MADE OF 30MnB5 WEAR-PROOF STEEL: THE STEEL THAT REALLY LASTS MORE

The 30MnB5 steel has chemical and mechanical characteristics that are absolutely superior to the commonly used steels. The high content of chromium and boron guarantees a real resistance, both mechanically and chemically, to the wear and tear caused by concrete.

Steel types

30MnB5: wear-proof steel that we use to construct the truck mixer drums
27MnB5 (TBL2A): wear-proof steel for agricultural machinery, harrows, ploughs
Fe510: steel commonly used for mechanical constructions

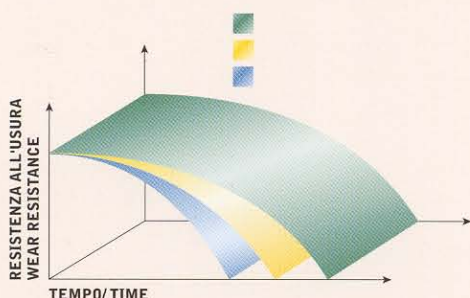

Tipo Type	Spessore Thickness (mm)	Re _H (N/mm ²)	R _{p0.2} (N/mm ²)	R _m (N/mm ²)	Allungamento Elongation A5 (%)	HB 30/10 (1/2)
30MnB5	4	492	492	700	23,0	200/220
27MnB5	4	392	392	615	26,2	179/179
Fe510	5	420	447	520	30	n.d.

caratteristiche tecniche technical data

Betoniera - Mixer

Capacità nominale - Nominal Capacity	3 m ³
Volume geometrico - Geometrical volume	5,528 m ³
Serbatoio acqua - Water tank	280 l
Lunghezza - Length	6773 mm
Altezza - Height	3310 mm
Peso veicolo (a vuoto) - Vehicle weight (empty)	8500 kg

Camion Mercedes Benz Unimog U500L Mercedes Benz Unimog U500L truck chassis

Potenza - Power	279 hp
Peso veicolo (a pieno carico) - Vehicle weight (loaded)	15000 kg

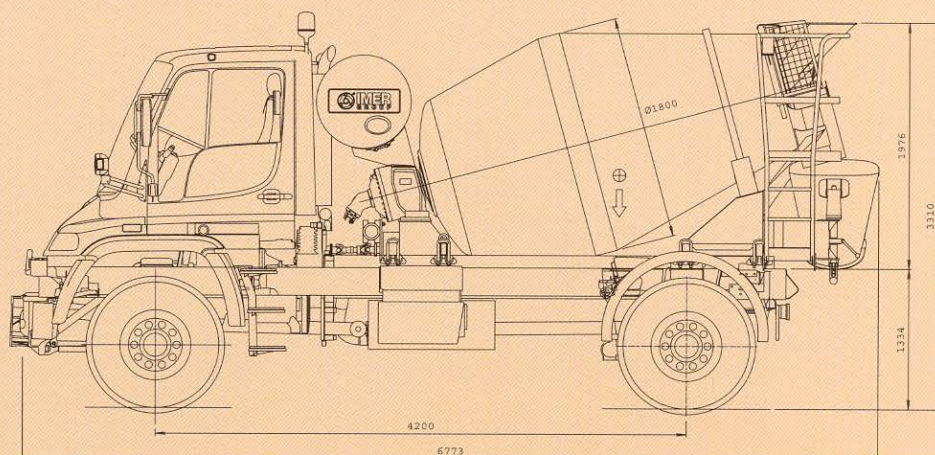

Le Officine Riunite - Udine S.p.A.

Concrete Machinery Division
Via Santa Caterina, 35 - 33030 Basaldella di Campofornido (Ud)
Tel. +39 0432 563911 - Fax +39 0432 562131
E-mail: oru@oru.it - www.imergroup.com

Le Officine Riunite - Udine S.p.A. si riservano il diritto di variare senza preavviso i dati esposti quando vi siano giustificati motivi. I dati e le misure non sono quindi da ritenersi impegnativi. Le illustrazioni possono contenere accessori e quindi non conformi alle versioni standard delle macchine.
Le Officine Riunite - Udine S.p.A. reserves the right to change the information contained herein without prior notice where they consider it justified. The data and dimensions are therefore not to be considered as binding. The illustrations may include accessories and therefore they could be slightly different from the standard versions of the equipment.