

LT 7.7D

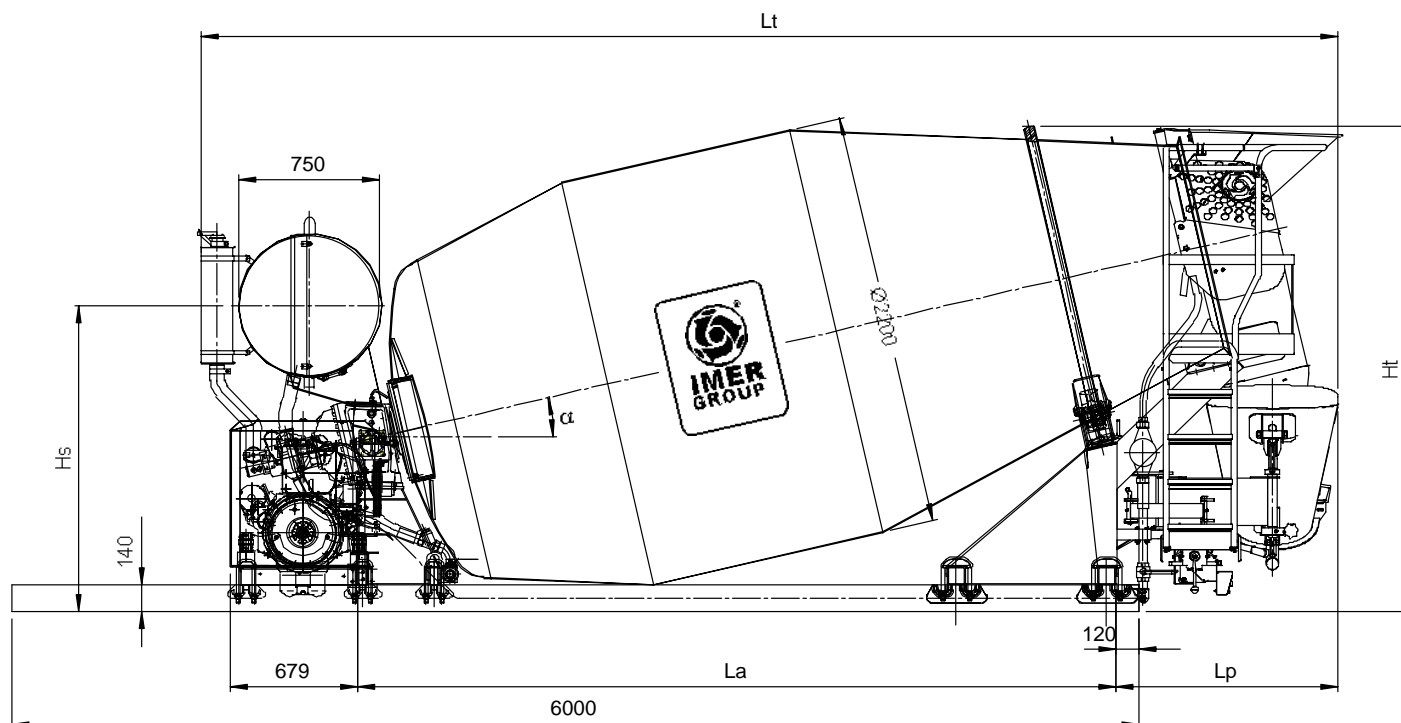

α	15 °
Ht	2665 mm
Hs	1564 mm
Lt	6072 mm
La	4020 mm
Lp	1184 mm

Data sheet

Nominal capacity	7(8) m ³
Geometrical volume	12,766 m ³
Capacity in water	8,279 m ³ l
Drum speed	0-14 rev/min
Filling capacity	15"/m ³
Unloading capacity	15"- 40"/m ³ depending on concrete slump
Weight (empty)	3.850 kg
Vehicle	6x4
Rollers	n. 2 diam. 280mm

Drum walls made in 30MnB5 anti-wear resistant steel - HB 200/220 N/mm² (4mm thickness)
 Mixing blades made in 30MnB5 anti-wear resistant steel - HB 200/220 N/mm² (4mm thickness)

Motion

D version: by Deutz F4L912 auxiliary engine, 4 cylinders, air cooled

LT 7.7D

Controls

By cable with control box

Hydrostatic transmission

Eaton 46.21 (75.3 cm³/rev) variable displacement hydraulic pump with 25 cm³/rev feeding pump

Eaton 46.31 (75.3 cm³/rev) fixed displacement hydraulic motor

OK 2.6 (60.000 Nm) double stage planetary gearbox

Oil cooler (42.000 BTU) built in oil tank, complete with cartridge filter with indicator and electric fan with thermostat

Control panel with led and acoustic alarm of oil overheating, electric fan and thermostat functioning. Working hour meter

Water system

650l steel water tank with level indicator

LT130 water pump (450 l/min at 4 BAR) driven by P.T.O. on gearbox

0-500l water meter

Standard features

- 180° swivelling discharging chute with support and mechanical jack for lifting
- 2 Polystone lightweight extension chutes with holders.
- Anti-wear resistant plate on discharging hopper
- Inspection manhole
- Inspection ladder
- Wash off hose on ladder pedestal
- Drum lock (for safety maintenance operations)
- Mixer frame "C" shaped
- Carrying rollers made in C45 special steel
- Steel surfaces shotblasted in SA 2,5 grade
- Double primed in antirust painting



Optionals / Variations

- Additional extension steel chute L=1000 mm
- Additional short extension steel chute L=500 mm
- Additional polystone extension chute (light construction) L=1000 mm
- Additional short polystone extension chute (light construction) L=500 mm
- Telescopic discharging chute LT 555 with funnel
- Funnel chute ø195 mm
- Hinged extension steel chute
- Hinged extension Polystone chute (light construction)
- Flap on discharging chute
- Anti wear protection sheet on feeding hopper
- Anti wear protection sheet on discharging chute
- Vibrator on discharging chute
- Half hydraulic drum cover
- Full hydraulic drum cover



LT 7.7D

- Hydraulic manometer with large gauge \varnothing 65 mm placed at the rear
- Hydraulic manometer with large gauge \varnothing 100 mm placed at the rear
- Water connection on two sides
- Additional valve for water tank closing
- Rear steel mud-guards and supports (one pair)
- Rear aluminium mud-guards and supports (one pair)
- Rear aluminium mud-guards with the smooth surface on the outside and supports (one pair)
- Mud-guards for front axle and supports (one pair)