

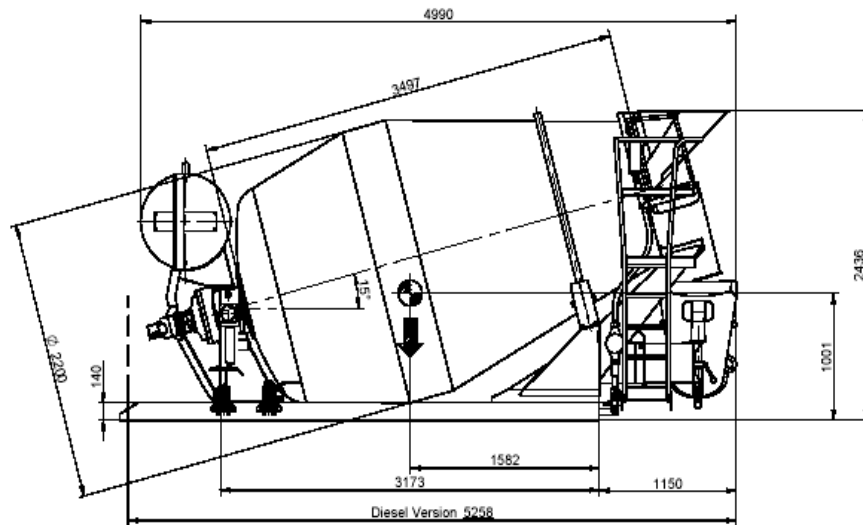

TRUCK MIXER LT 50D



THE CENTER OF GRAVITY DIMENSION ARE REFERRED TO THE MIXER SUB-FRAME.

Data sheet

Nominal capacity	5 m ³
Geometrical volume	8,800 m ³
Capacity in water	5.400 l
Drum speed	0-14 rev/min
Filling capacity	10"/m ³
Unloading capacity	10" - 40"/m ³ depending on concrete slump
Drum angle	15°

Drum walls made in 30MnB5 anti-wear resistant steel - HB 200/220 N/mm² (4mm thickness)
Mixing blades made in 30MnB5 anti-wear resistant steel - HB 200/220 N/mm² (4mm thickness)

Motion

By Deutz F4L912 auxiliary engine, 4 cylinders, air cooled.

Controls

By cable with control box.

Hydrostatic transmission

Eaton 46.21 (75.3 cm³/rev) variable displacement hydraulic pump with 25 cm³/rev feeding pump.
Eaton 46.31 (75.3 cm³/rev) fixed displacement hydraulic motor.
LT OK6000 double stage planetary gearbox, max. output torque: 58.000 Nm.
Oil cooler (42.000 BTU) built in oil tank, complete with cartridge filter with indicator and electric fan with thermostat.

TRUCK MIXER LT 50D



Control panel with led and acoustic alarm of oil overheating, electric fan and thermostat functioning.

Working hour meter.

Water system

650l steel water tank with level indicator.

LTC30 water pump (450 l/min at 4 BAR) belt driven.

0-500l water meter.

Standard features

- 180° swivelling discharging chute with support and mechanical jack for lifting.
- 2 Polystone lightweight extension chutes with holders.
- Anti-wear resistant plate on discharging hopper.
- Inspection manhole.
- Inspection ladder.
- Wash off hose on ladder pedestal.
- Drum lock (for safety maintenance operations).



Mixer frame “C” shaped.

Carrying rollers made in C45 special steel.

Steel surfaces shotblasted in SA 2,5 grade.

Double primer antirust painting.

Optionals / Variations

- Additional extension steel chute L=1000 mm
- Additional short extension steel chute L=500 mm
- Additional polystone extension chute (light construction) L=1000 mm
- Additional short polystone extension chute (light construction) L=500 mm
- Telescopic discharging chute LT 555 with funnel
- Funnel chute \varnothing 195 mm
- Hinged extension steel chute
- Hinged extension Polystone chute (light construction)
- Flap on discharging chute
- Anti wear protection sheet on feeding hopper
- Anti wear protection sheet on discharging chute
- Vibrator on discharging chute
- Half hydraulic drum cover
- Full hydraulic drum cover
- Hydraulic manometer with large gauge \varnothing 65 mm placed at the rear
- Hydraulic manometer with large gauge \varnothing 100 mm placed at the rear
- Water connection on two sides
- Additional valve for water tank closing
- Rear steel mud-guards and supports (one pair)
- Rear aluminium mud-guards and supports (one pair)
- Rear aluminium mud-guards with the smooth surface on the outside and supports (one pair)
- Mud-guards for front axle and supports (one pair)