

LT 3.7H

BUGMIXER

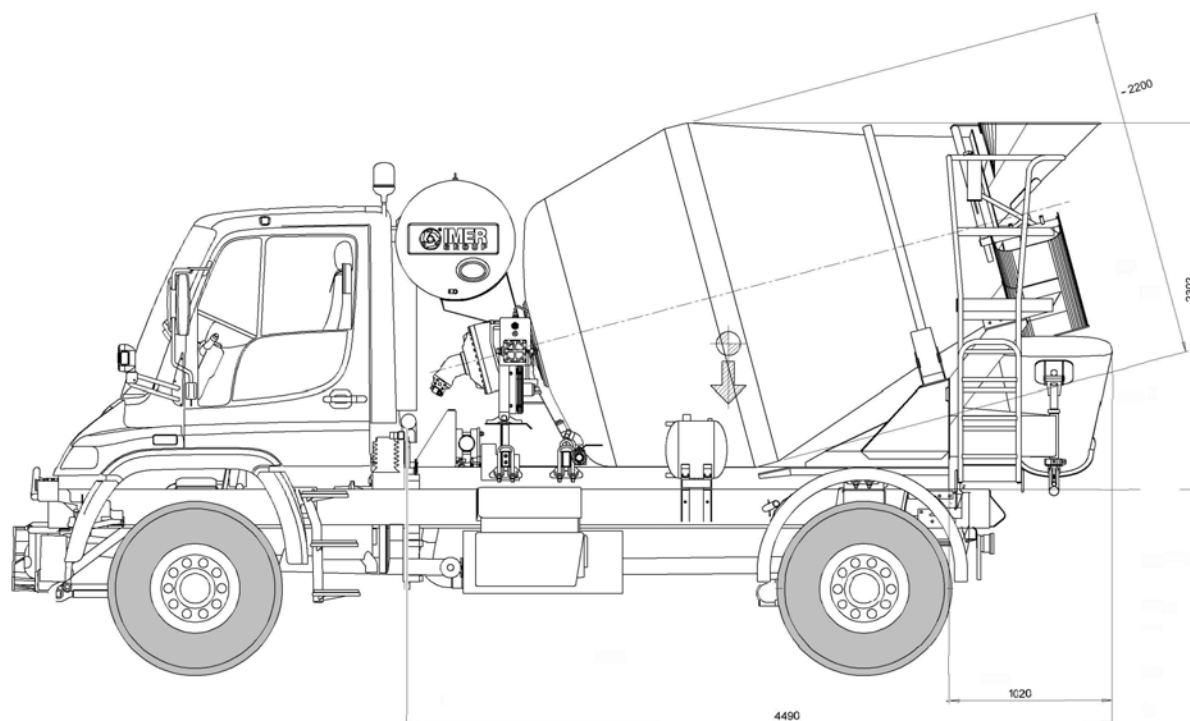

### Data sheet

|                    |                      |
|--------------------|----------------------|
| Nominal capacity   | 3(4) m <sup>3</sup>  |
| Geometrical volume | 6,748 m <sup>3</sup> |
| Capacity in water  | 4,043 m <sup>3</sup> |
| Drum speed         | 0-14 rev/min         |
| Filling ratio      | 60%                  |
| Water tank         | 280l                 |
| Weight             | 2.650 kg             |

### Motion

By P.T.O. on truck engine (excluded from our supply)

### Controls

By cable with control box

### Water system

280l steel water tank with level indicator

LT 3.7H

BUGMIXER



### Outstanding characteristics

- 2 stage **epicyclical gear-box**. Hydrostatic transmission with closed circuit consisting of a pump with axial pistons, a motor with axial pistons and integrated speed transducer, CSD electronic system (**Constant Speed Drive**)
- Ergonomic and user-friendly **JOY Pushbutton controls**
- **Pressurized INOX additive tank** (option)
- **Superlight polystone extension** chute and cyclist side-protection
- **Heat exchanger** with built-in filter and oil tank
- Ergonomic ladder
- **Mechanical lock against rotation** to allow maintenance of the drum in full safety
- **Hydraulic controls** with distributor